

# serie **idea**

NG280 - NG350 - NG400

NG550

gas

Con la introducción de la nueva línea de quemadores IDEA, CIB UNIGAS se presenta en el mercado con una solución de reciente concepción en cuanto estética y funcionalidad en el campo de quemadores de pequeña y media potencialidad. Estas nuevas máquinas, la versión más potente de la nueva gama IDEA, destacan por sus elevadas prestaciones y amplitud del campo de trabajo, con elevadas presiones en la cámara de combustión. En particular, los modelos NG350 y 400 utilizan una tobera en versión "Modular" apta para soluciones tanto estándar como especiales.

La entera gama de la serie es el resultado de políticas de inversión finalizadas a la búsqueda de soluciones avanzadas a nivel tecnológico. La particular geometría de la válvula de mariposa ha sido estudiada para obtener una proporción lineal entre el ángulo de apertura y el caudal, asegurando una combustión progresiva, regular y eficiente en todo el rango de empleos.

Todas las versiones del quemador se caracterizan por algunas útiles soluciones funcionales: acoplamiento rápido a la línea de alimentación, componentes mecánicos montados en una placa de soporte del quemador desmontable que agiliza las operaciones de mantenimiento, toma de presión en la cámara de combustión y brida de unión de profundidad reducida para satisfacer las exigencias de reducción de las medidas. La posición del cabezal se regula con un tornillo graduado. Además, la rampa del gas con sus relativas uniones se monta tanto a la derecha como a la izquierda del quemador.

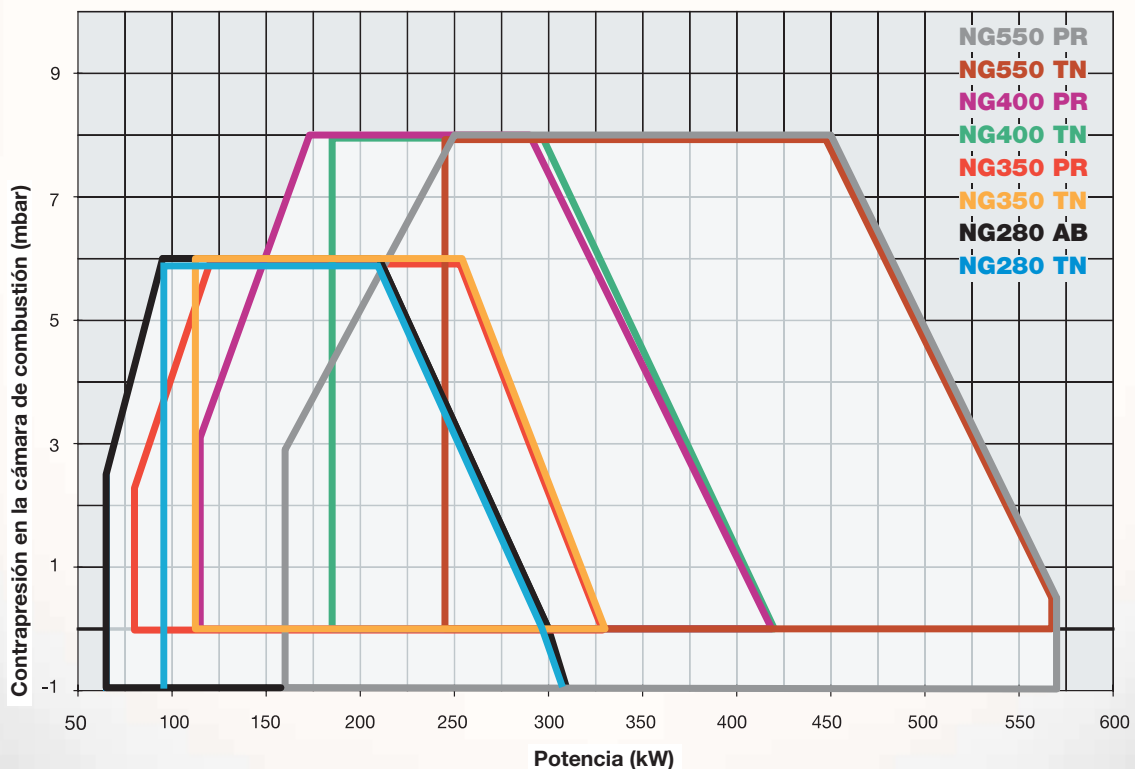

## CARACTERÍSTICAS TÉCNICAS

Tipo	Modelo	Potencia kW		Alimentación eléctrica	Motor 2800 g/1'	Uniones gas Rp
		mín.	máx.			
<b>NG280</b>	M-.TN.x.IT.A.0.xx	95	300	230V 1N ac	0.25	1" - 1"1/4 - 1"1/2
<b>NG280</b>	M-.AB.x.IT.A.0.xx	65	300	230V 1N ac	0.25	1" - 1"1/4 - 1"1/2
<b>NG350</b>	M-.TN.M.IT.A.0.xx	115	330	230V 1N ac	0.37	1" - 1"1/4 - 1"1/2
<b>NG350</b>	M-.PR.M.IT.A.0.xx	80	330	230V 1N ac	0.37	1" - 1"1/4 - 1"1/2
<b>NG400</b>	M-.TN.M.IT.A.0.xx	185	420	230V 1N ac	0.45	1" - 1"1/4 - 1"1/2 - 2"
<b>NG400</b>	M-.PR.M.IT.A.0.xx	115	420	230V 1N ac	0.45	1" - 1"1/4 - 1"1/2 - 2"
<b>NG550</b>	M-.TN.x.IT.A.0.xx	245	570	230V 1N ac	0.62	1"1/4 - 1"1/2 - 2"
<b>NG550</b>	M-.PR.x.IT.A.0.xx	160	570	230V 1N ac	0.62	1"1/4 - 1"1/2 - 2"

Para la configuración de la rampa gas véase págs. 68-69.

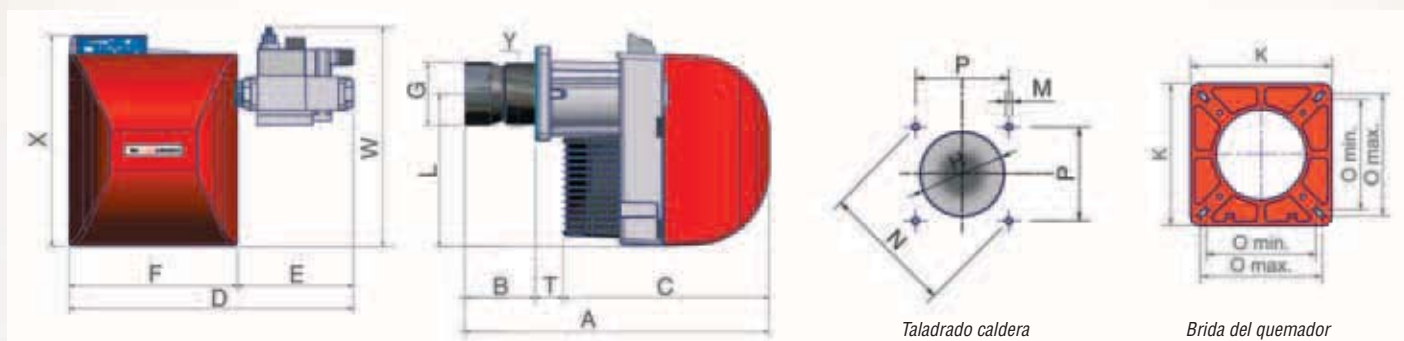

Tipo	Dimensiones de embalaje* (mm)			
	L	P	H	kg
<b>NG280</b>	800	480	540	42
<b>NG350</b>	800	480	540	42
<b>NG400</b>	800	480	540	45
<b>NG550</b>	1030	530	590	57

\* Valores indicativos

Tipo	Modelo	Dimensiones totales* (mm)										Taladrado caldera* (mm)				Brida del quemador* (mm)			
		A	AL	B	BL	C	F	G	L	T	X	Y	H	M	N	P	K	O mín máx	
<b>NG280</b>	M-.xx.x.IT.A.x.xx	750	880	178	308	572	395	117	347	90	491	144	164	M10	219	155	223x215	131	179
<b>NG350</b>	M-.xx.M.IT.A.0.xx	750	880	178	308	572	395	125	347	90	491	144	164	M10	219	155	223x215	131	179
<b>NG400</b>	M-.xx.M.IT.A.0.xx	770	900	198	328	572	395	144	347	90	491	144	164	M10	219	155	223x215	131	179
<b>NG550</b>	M-.xx.x.IT.A.0.xx	842	942	253	353	589	426	165	384	70	536	165	178	M10	247	174	241	157	192

\* Valores indicativos

Tipo	Modelo	Dimensiones totales* (mm)											
		E				D				W			
		Rp 1"	Rp 1"1/4	Rp 1"1/2	Rp 2"	Rp 1"	Rp 1"1/4	Rp 1"1/2	Rp 2"	Rp 1"	Rp 1"1/4	Rp 1"1/2	Rp 2"
<b>NG280</b>	M-.xx.x.IT.A.x.xx	215	215	343	-	611	611	739	-	473	508	568	-
<b>NG350</b>	M-.xx.M.IT.A.0.xx	215	215	343	-	611	611	739	-	473	508	568	-
<b>NG400</b>	M-.xx.M.IT.A.0.xx	215	215	343	343	611	611	739	739	473	508	568	568
<b>NG550</b>	M-.xx.x.IT.A.0.xx	-	296	369	369	-	722	795	795	-	543	553	603

\* Valores indicativos

Modelo	Rampa gas	Regulación	NG280		NG350	
			Código	Precio €	Código	Precio €
M-.TN.M.IT.A.0.25	1"	TN	-	-	027010141	-
M-.TN.M.IT.A.0.32	1"1/4	TN	-	-	027010241	-
M-.TN.M.IT.A.0.40	1"1/2	TN	-	-	027010341	-
M-.PR.M.IT.A.0.25	1"	PR	-	-	027010143	-
M-.PR.M.IT.A.0.32	1"1/4	PR	-	-	027010243	-
M-.PR.M.IT.A.0.40	1"1/2	PR	-	-	027010343	-
M-.MD.M.IT.A.0.25	1"	MD(*)	-	-	027010144	-
M-.MD.M.IT.A.0.32	1"1/4	MD(*)	-	-	027010244	-
M-.MD.M.IT.A.0.40	1"1/2	MD(*)	-	-	027010344	-
M-.TN.S.IT.A.0.25	1"	TN	027011741	-	-	-
M-.TN.L.IT.A.0.25	1"	TN	027011841	-	-	-
M-.TN.S.IT.A.0.32	1"1/4	TN	027011941	-	-	-
M-.TN.L.IT.A.0.32	1"1/4	TN	027012041	-	-	-
M-.TN.S.IT.A.0.40	1"1/2	TN	027012141	-	-	-
M-.TN.L.IT.A.0.40	1"1/2	TN	027012241	-	-	-
M-.AB.S.IT.A.0.25	1"	AB	027011742	-	-	-
M-.AB.L.IT.A.0.25	1"	AB	027011842	-	-	-
M-.AB.S.IT.A.0.32	1"1/4	AB	027011942	-	-	-
M-.AB.L.IT.A.0.32	1"1/4	AB	027012042	-	-	-
M-.AB.S.IT.A.0.40	1"1/2	AB	027012142	-	-	-
M-.AB.L.IT.A.0.40	1"1/2	AB	027012242	-	-	-

(\*) = Para completar el suministro es necesario dotar el quemador con la relativa sonda modulante (véase la tabla de accesorios pág. 65)

Conformes a la DIRECTIVA GAS 90/396/CEE

Modelo	Rampa gas	Regulación	NG400		NG550	
			Código	Precio €	Código	Precio €
M-.TN.M.IT.A.0.25	1"	TN	027010441		-	
M-.TN.M.IT.A.0.32	1"1/4	TN	027010541		-	
M-.TN.M.IT.A.0.40	1"1/2	TN	027010641		-	
M-.TN.M.IT.A.0.50	2"	TN	027010741		-	
M-.PR.M.IT.A.0.25	1"	PR	027010443		-	
M-.PR.M.IT.A.0.32	1"1/4	PR	027010543		-	
M-.PR.M.IT.A.0.40	1"1/2	PR	027010643		-	
M-.PR.M.IT.A.0.50	2"	PR	027010743		-	
M-.MD.M.IT.A.0.25	1"	MD(*)	027010444		-	
M-.MD.M.IT.A.0.32	1"1/4	MD(*)	027010544		-	
M-.MD.M.IT.A.0.40	1"1/2	MD(*)	027010644		-	
M-.MD.M.IT.A.0.50	2"	MD(*)	027010744		-	
M-.TN.S.IT.A.0.32	1"1/4	TN	-		028010141	
M-.TN.L.IT.A.0.32	1"1/4	TN	-		028010241	
M-.TN.S.IT.A.0.40	1"1/2	TN	-		028010341	
M-.TN.L.IT.A.0.40	1"1/2	TN	-		028010441	
M-.TN.S.IT.A.0.50	2"	TN	-		028010541	
M-.TN.L.IT.A.0.50	2"	TN	-		028010641	
M-.PR.S.IT.A.0.32	1"1/4	PR	-		028010143	
M-.PR.L.IT.A.0.32	1"1/4	PR	-		028010243	
M-.PR.S.IT.A.0.40	1"1/2	PR	-		028010343	
M-.PR.L.IT.A.0.40	1"1/2	PR	-		028010443	
M-.PR.S.IT.A.0.50	2"	PR	-		028010543	
M-.PR.L.IT.A.0.50	2"	PR	-		028010643	
M-.MD.S.IT.A.0.32	1"1/4	MD(*)	-		028010144	
M-.MD.L.IT.A.0.32	1"1/4	MD(*)	-		028010244	
M-.MD.S.IT.A.0.40	1"1/2	MD(*)	-		028010344	
M-.MD.L.IT.A.0.40	1"1/2	MD(*)	-		028010444	
M-.MD.S.IT.A.0.50	2"	MD(*)	-		028010544	
M-.MD.L.IT.A.0.50	2"	MD(*)	-		028010644	

(\*) = Para completar el suministro es necesario dotar el quemador con la relativa sonda modulante (véase la tabla de accesorios pág. 65)

Conformes a la DIRECTIVA GAS 90/396/CEE

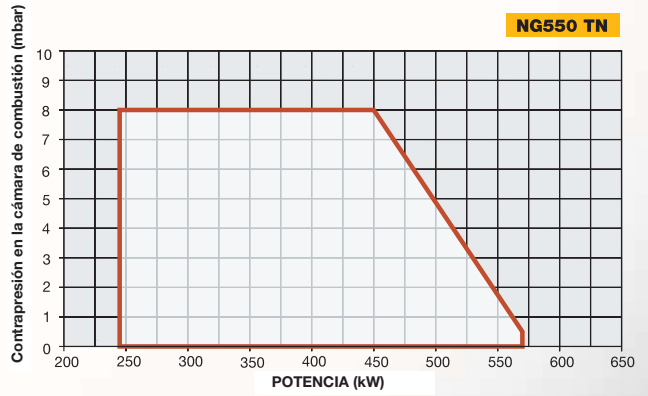
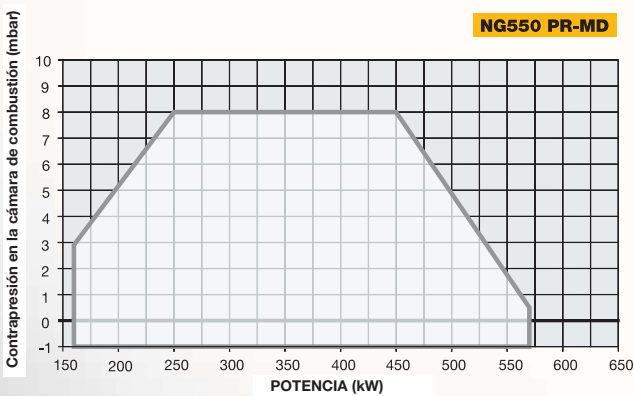
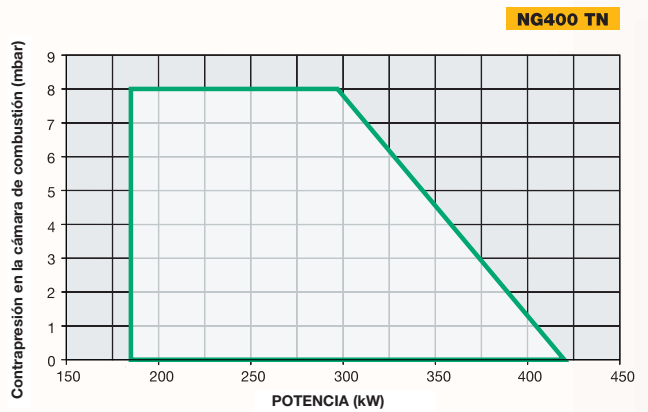
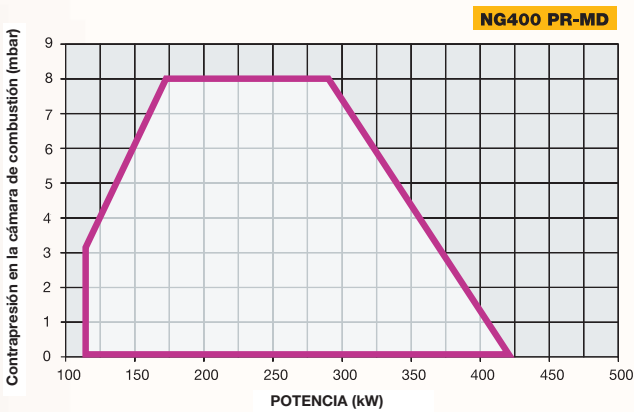
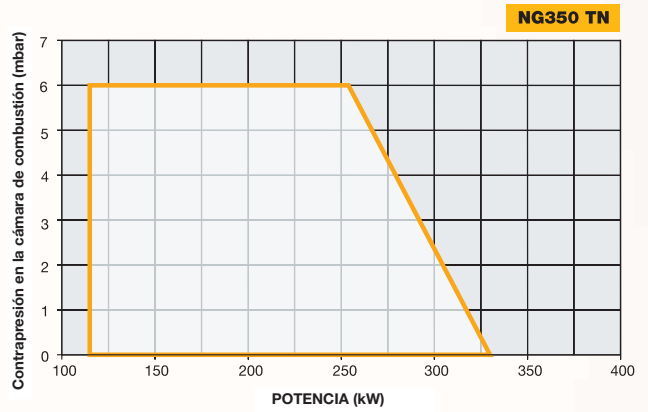
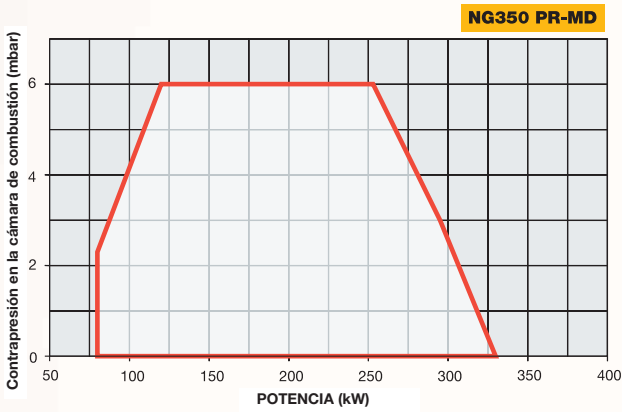
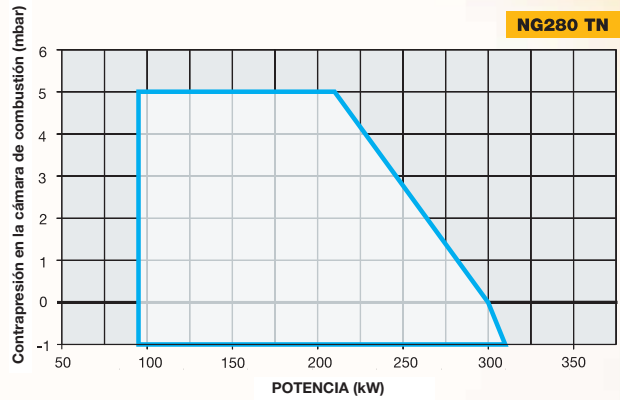
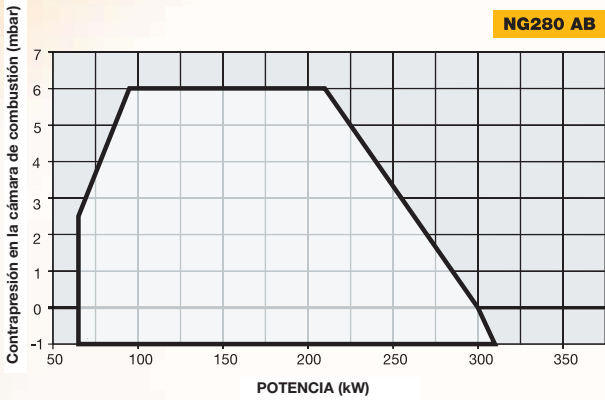

**NG280 AB**

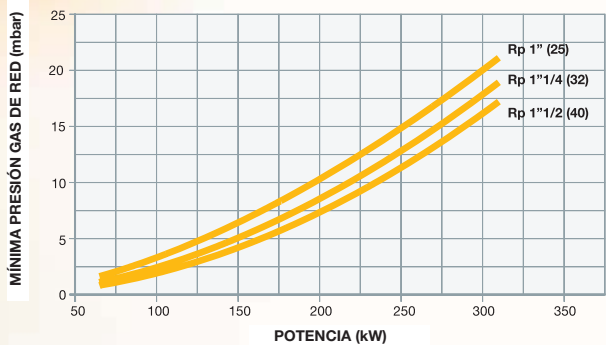

**NG280 TN**

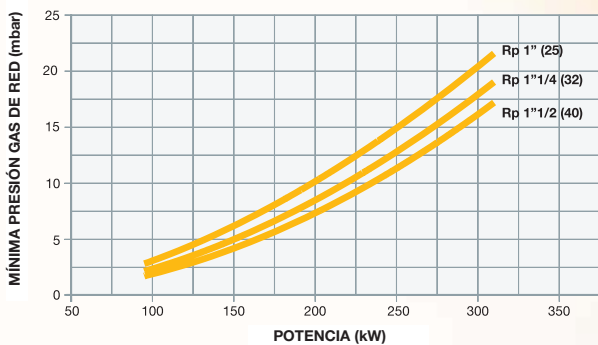

**NG350 PR-MD**

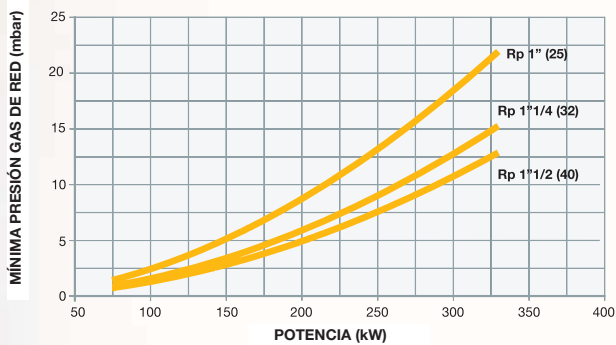

**NG350 TN**

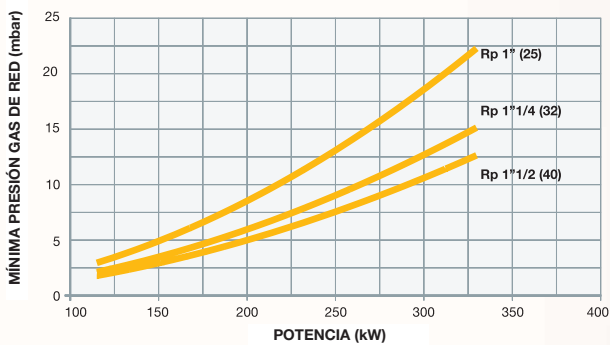

**NG400 PR-MD**

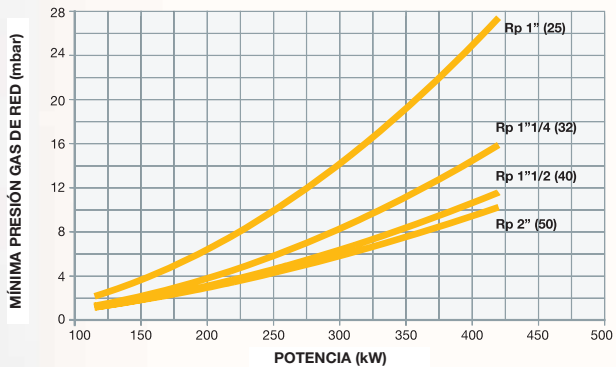

**NG400 TN**

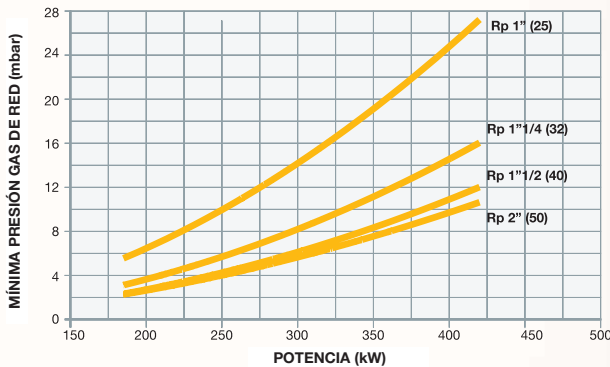

**NG550 PR-MD**

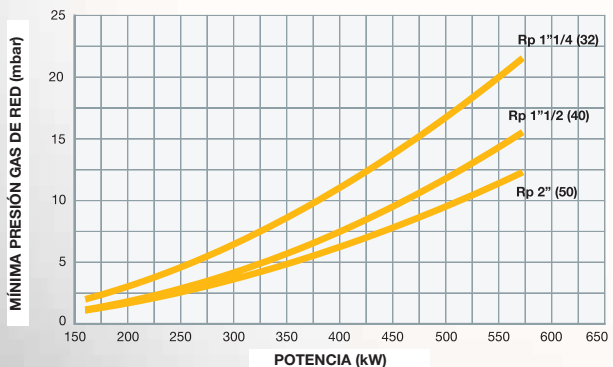

**NG550 TN**

