



SISTEMA DE GESTIÓN DE COMBUSTIBLE



DISPENSADORES



KITS



BOMBAS



MEDIDORES



PISTOLAS

# PIUSI HAND PUMP

## CARACTERÍSTICAS

- CAPACIDAD DE SUCCIÓN OPTIMIZADA
- CONECTOR ROBUSTO
- PALANCA RESISTENTE
- REVOLUCIÓN FLUIDA
- ALTA EFICIENCIA
- TUBO DE SUCCIÓN AJUSTABLE

PIUSI HAND PUMP es una bomba giratoria de paletas adecuada para transferir aceites de baja viscosidad y diésel. Totalmente diseñada, fabricada y certificada en Italia, esta robusta bomba garantiza un rendimiento profesional y una transferencia sencilla.

**CaleMur.es**

### RENDIMIENTO

HASTA

**38L**

POR 100 REVOLUCIONES

CAUDAL

**3MT**

LONGITUD  
MANGUERA DE  
SUMINISTRO



PIUSI HAND PUMP CON MANGUERA Y BOQUILLA DE ACERO INOXIDABLE



### PACKAGING

CÓDIGO	PESO		PACKAGING			N. BOX / EUROPALET	
	KG	LBS	MM	PULGADAS	UDS./CAJA	✈	🚚
<b>SIN MANGUERA</b>							
FO033250A	2,1	4,6	350X170X140	-	1	50	100
<b>CON MANGUERA</b>							
FO033252A	3,2	7	300X300X180	-	1	50	100



FILTRACIÓN



MONITOREO DE DEPOSITO



ENROLLADORES DE MANGUERA



ACCESORIOS



MATERIAL PROMOCIONAL



AIRE



ANTICONG.



AdBlue®



BIODIÉSEL



DIÉSEL



ALIMENTOS



GASOLINA



GRASA



QUEROSENO



ACEITE



AGUA



LIMPIAPARAB.

## GRÁFICO

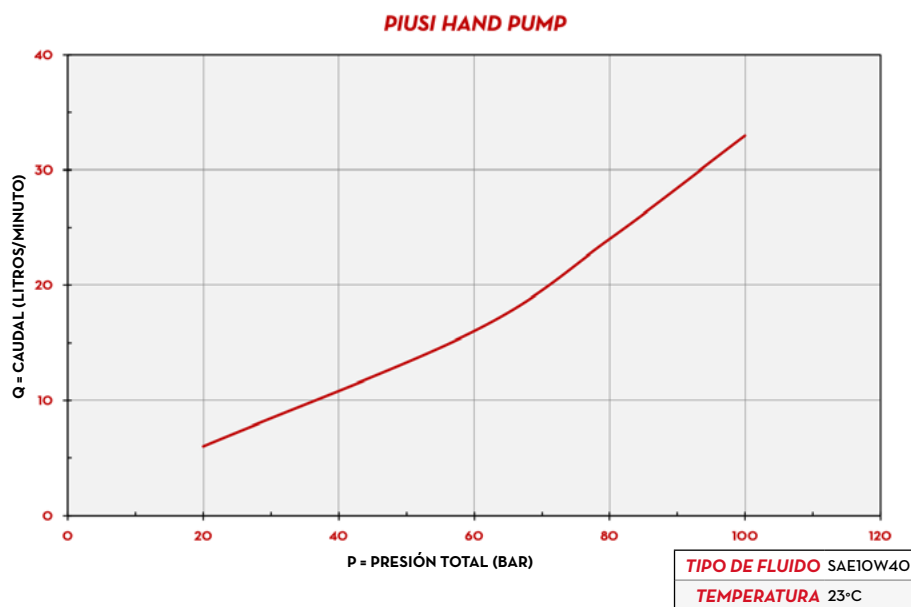

## DIMENSIONES

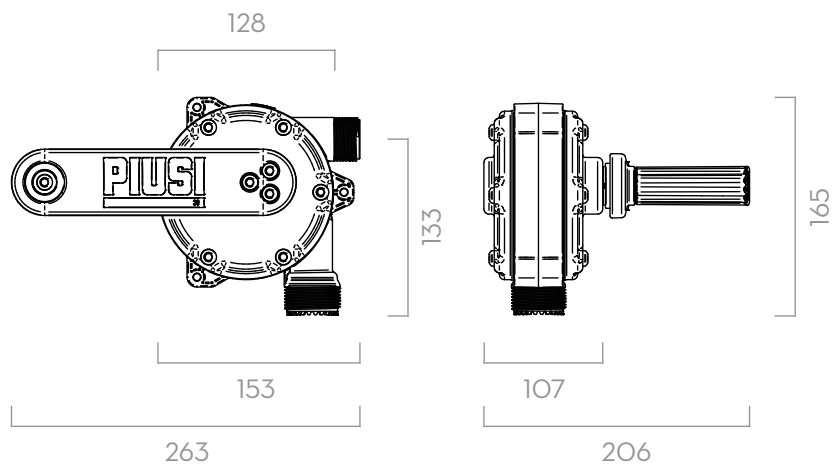

Las dimensiones se expresan en milímetros

## CONTENIDO DE LA CAJA

- PIUSI HAND PUMP
- BOQUILLA
- TUBO DE SUCCIÓN
- CONECTOR PARA BIDÓN
- MANUAL DE INSTRUCCIONES

## DETALLES



## MATERIALES

- CUERPO: ACERO INOXIDABLE, TECNOPOLÍMERO
- ROTOR: TECNOPOLÍMERO
- PALETAS: TECNOPOLÍMERO

## FICHA TÉCNICA

CÓDIGO	DESCRIPCIÓN	TIPO DE FLUIDO	CAPACIDAD POR 100 REVOLUCIONES		CONECTOR PARA BIDÓN	TUBO DE SUCCIÓN	BOQUILLA 1/2" Y TERMINAL MANGUERA	LONGITUD MANGUERA SUMINISTRO
			L	USG				
<b>SIN MANGUERA</b>								
FO033250A	PIUSI HAND PUMP 2" BSP	<span style="color: green;">D</span> <span style="color: orange;">O</span>	38	10	2" BSP	sí	sí	-
<b>CON MANGUERA</b>								
FO033252A	KIT PIUSI HAND PUMP 2" BSP WITH HOSE	<span style="color: green;">D</span> <span style="color: orange;">O</span>	38	10	2" BSP	sí	-	3M

# PIUSI HAND PUMP